

|      |          | Parts List                    |  |
|------|----------|-------------------------------|--|
| ITEM | PART #   | DESCRIPTION                   | NOTES  |
| 1    | K1570-50 | Series 7 Bleed Body Assembly  | Slide assemble into post   |
| 2    | 1550     | Series 7 Reveal               | Attached to Body   |
| 3    | 1500-50  | Series 7 Radius Post Assembly |  |
| 4    | Post Cap | Series 7 Radius Post Cap      | Zero Reveal Part #5020, 1/2" Reveal Part #5024, 1" Reveal Part #5026 |
| 41   | 5040     | Cap Screw                     | 2 - #10 x 1/2" counter sink phillips head screws                     |

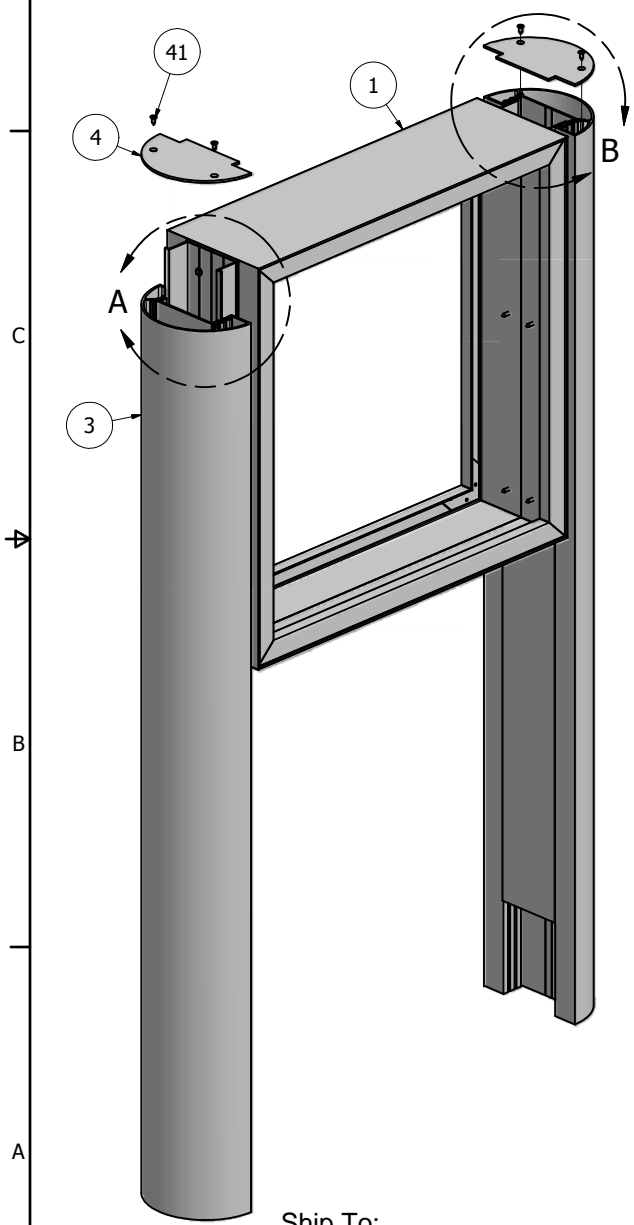

Ship To:  
Order #:

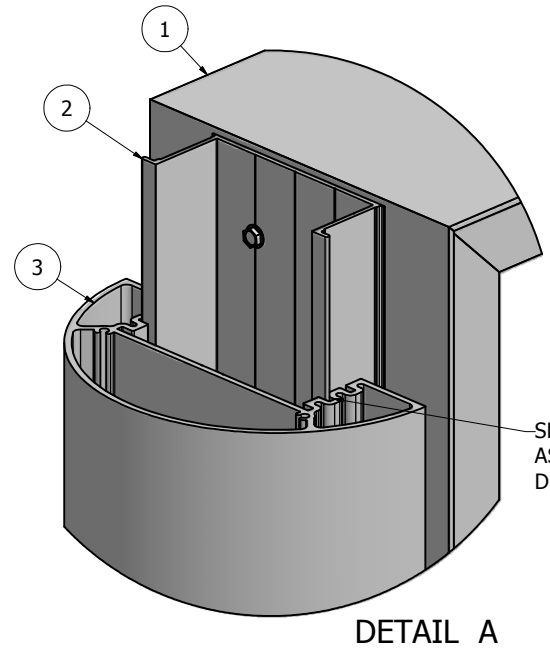

DETAIL A

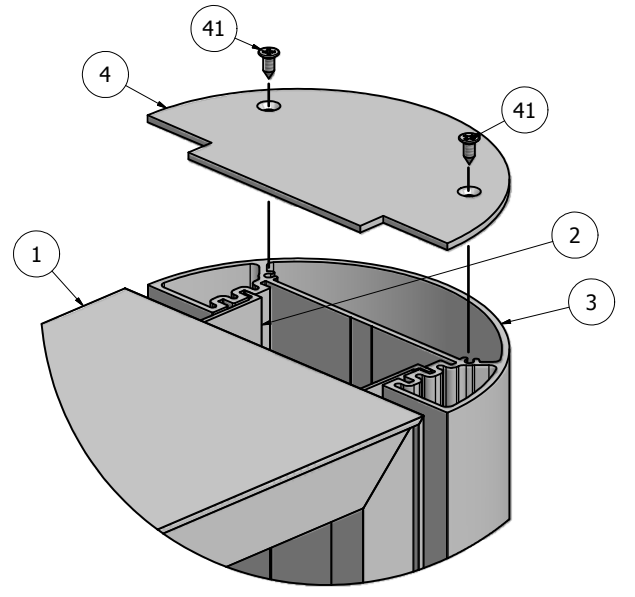

DETAIL B

SLIDE BODY/CABINET ASSEMBLY INTO THE DESIRED REVEAL POSITION.

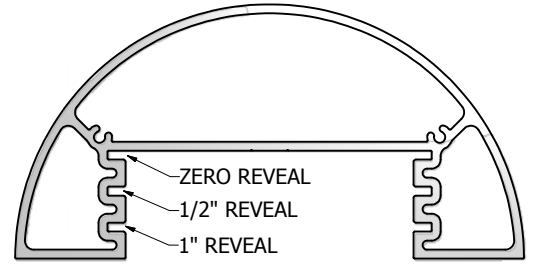
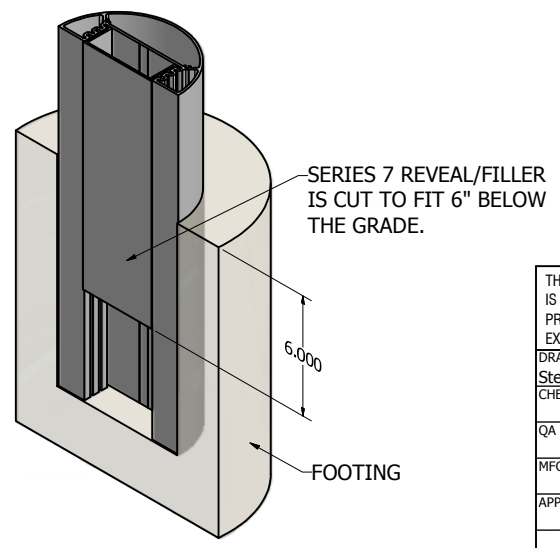

**NOTE: PRE-CUT KITS ARE NOT PRE-DRILLED.**  
(Holes shown in this drawing are for reference only. Drilling of pilot holes are to be done by fabricator.)

|   |          |   |              |
|---|----------|---|--------------|
| THIS DRAWING WAS CREATED AT NO CHARGE TO ASSIST YOU IN VISUALIZING OUR PROPOSAL. THE DRAWING HEREIN IS THE PROPERTY OF SIGNCOMP. PERMISSION TO COPY OR REVISE THIS DRAWING OR TO USE THIS DRAWING FOR PRODUCTION IS STRICTLY PROHIBITED AND CAN ONLY BE COPIED, REVISED OR USED FOR PRODUCTION WITH THE EXPRESSED WRITTEN PERMISSION OF SIGNCOMP. |          |   |              |
| DRAWN   | 8/6/2009 | <b>SignComp</b>                                       |              |
| Steve   |          |   |              |
| CHECKED   |          | TITLE   |              |
| QA  |          | Series 7 Bleed Body - Series 7 Radius Post - Assembly |              |
| MFG   |          | SIZE  | DWG NO       |
| APPROVED  |          | C   | K1570-00     |
|   |          | SCALE   | REV          |
|   |          |   | SHEET 1 OF 1 |

| Parts List |        |                     |              |
|------------|--------|---------------------|--------------|
| ITEM       | PART # | DESCRIPTION         | NOTES        |
| 1          | 1570   | Series 7 Bleed Body | Top & Bottom |
| 2          | 1570   | Series 7 Bleed Body | Sides        |
| 3          | 5210   | Corner Key          |              |

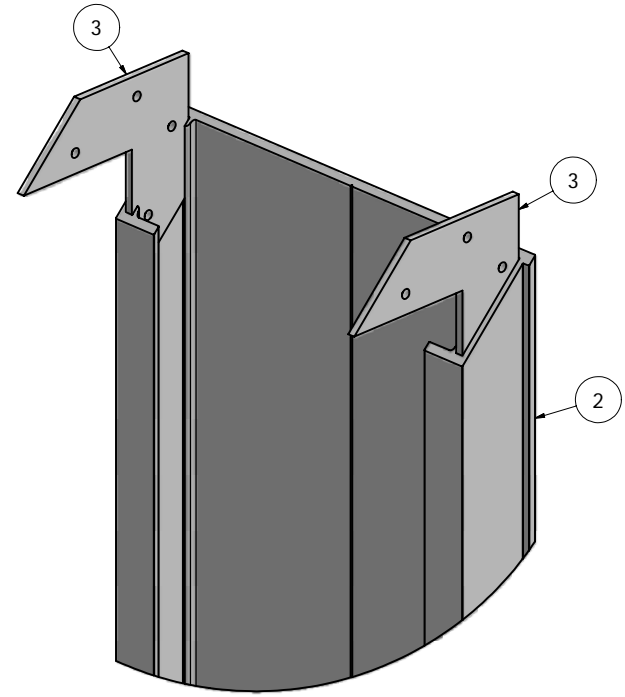
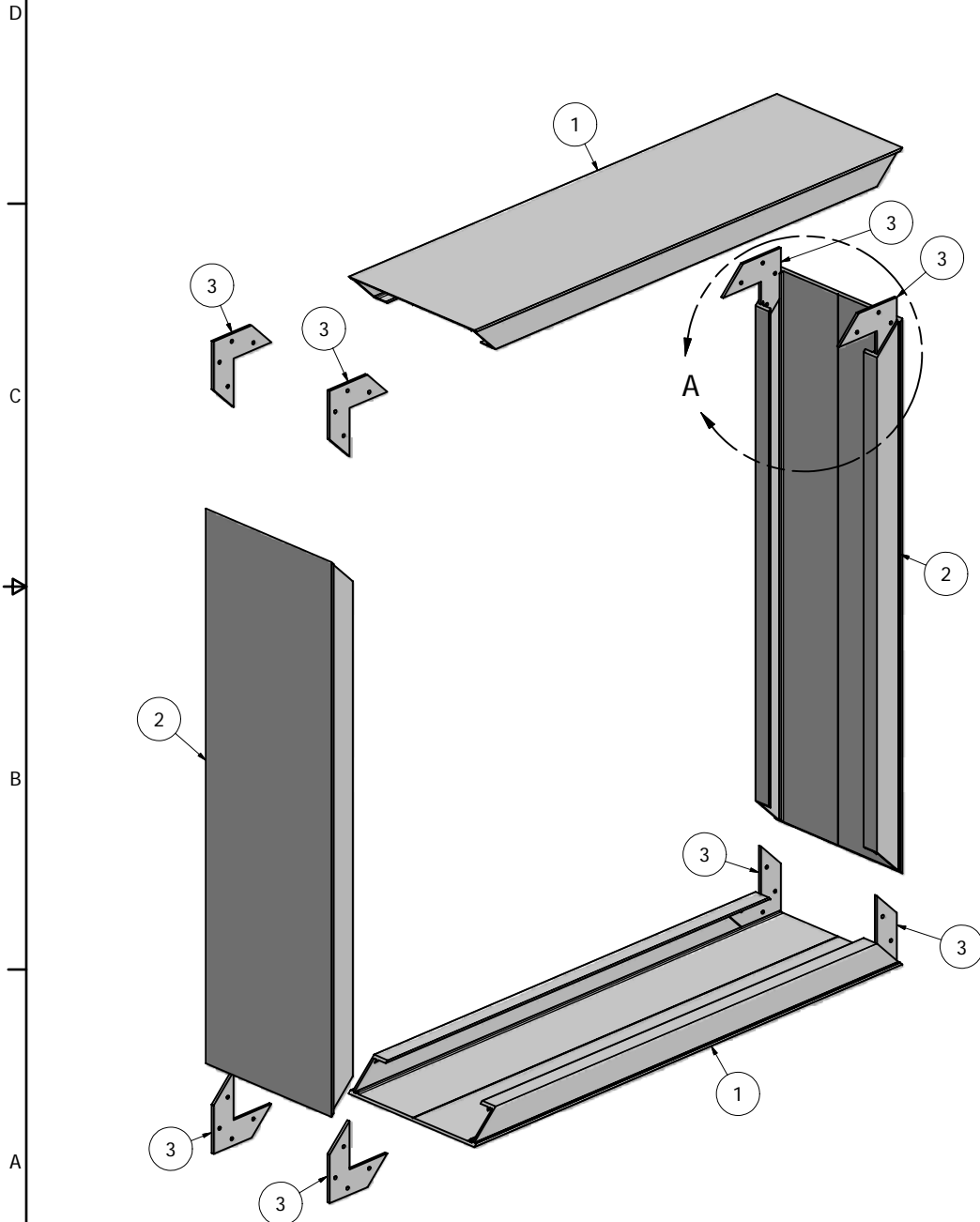

DETAIL A

**NOTE: PRE-CUT KITS ARE NOT PRE-DRILLED.**

(Holes shown in this drawing are for reference only.  
Drilling of pilot holes are to be done by fabricator.)

THIS DRAWING WAS CREATED AT NO CHARGE TO ASSIST YOU IN VISUALIZING OUR PROPOSAL. THE DRAWING HEREIN IS THE PROPERTY OF SIGNCOMP. PERMISSION TO COPY OR REVISE THIS DRAWING OR TO USE THIS DRAWING FOR PRODUCTION IS STRICTLY PROHIBITED AND CAN ONLY BE COPIED, REVISED OR USED FOR PRODUCTION WITH THE EXPRESSED WRITTEN PERMISSION OF SIGNCOMP.

|          |       |          |   |       |     |  |
|----------|-------|----------|---|-------|-----|--|
| DRAWN    | Steve | 2/6/2009 | <h1>SignComp</h1> <p>Series 7 Bleed Body - Assembly</p> |       |     |  |
| CHECKED  |       |          |   |       |     |  |
| QA       |       |          |   |       |     |  |
| MFG      |       |          |   |       |     |  |
| APPROVED |       |          |   |       |     |  |
|          | SIZE  | C        | DWG NO  | K1570 | REV |  |
|          | SCALE |          | SHEET 1 OF 1  |       |     |  |

Ship To:

Order #:

| Parts List |        |                      |  |
|------------|--------|----------------------|--|
| ITEM       | PART # | DESCRIPTION          | NOTES                                  |
| 1          | 1570   | Series 7 Bleed body  | Assembly                               |
| 2          | 1550   | Series 7 Reveal      | Attach to Bleed Body                   |
| 3          | 5220   | Reveal to Body Screw | Drill 3/32" Pilot Hole in pairs 12" OC |

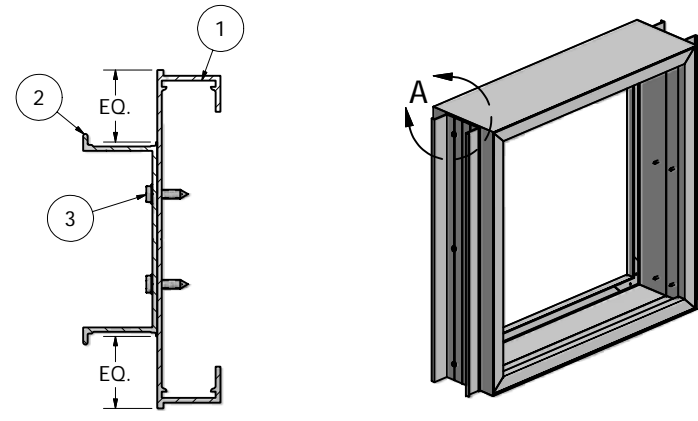
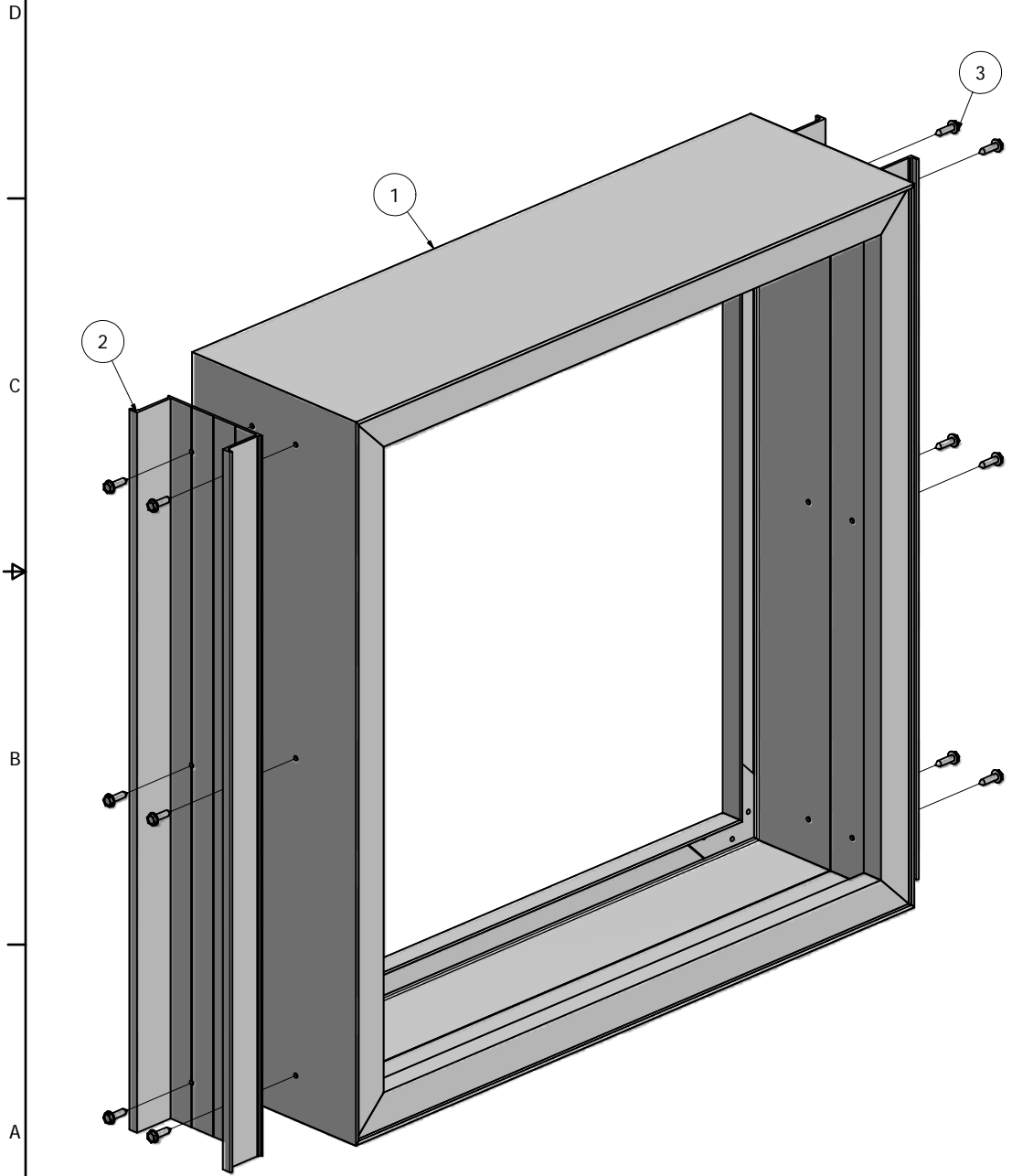

SECTION B-B

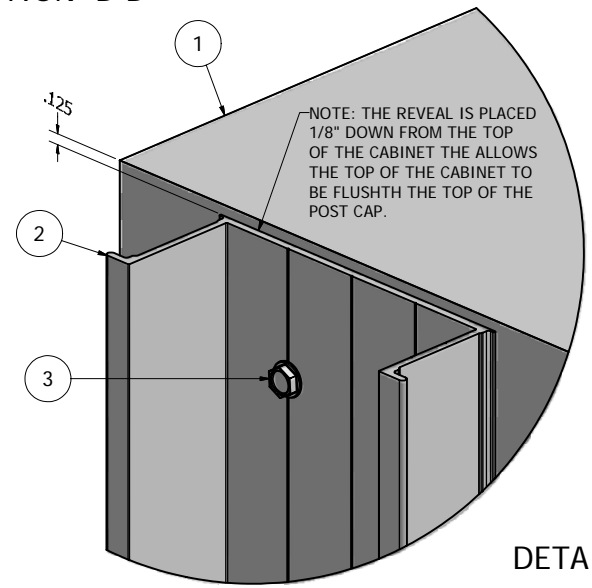

DETAIL A

**NOTE: PRE-CUT KITS ARE NOT PRE-DRILLED.**  
 (Holes shown in this drawing are for reference only.  
 Drilling of pilot holes are to be done by fabricator.)

Ship To:  
 Order #:

THIS DRAWING WAS CREATED AT NO CHARGE TO ASSIST YOU IN VISUALIZING OUR PROPOSAL. THE DRAWING HEREIN IS THE PROPERTY OF SIGNCOMP. PERMISSION TO COPY OR REVISE THIS DRAWING OR TO USE THIS DRAWING FOR PRODUCTION IS STRICTLY PROHIBITED AND CAN ONLY BE COPIED, REVISED OR USED FOR PRODUCTION WITH THE EXPRESSED WRITTEN PERMISSION OF SIGNCOMP.

|          |          |  |              |
|----------|----------|--|--------------|
| DRAWN    | 8/5/2009 | <b>SignComp</b>                                      |              |
| CHECKED  |          |  |              |
| QA       |          | TITLE  |              |
| MFG      |          | K1570 with Series 7 Reveal - Reval Attachment Detail |              |
| APPROVED |          | SIZE   | DWG NO       |
|          |          | C  | K1570-50     |
|          |          | SCALE  | REV          |
|          |          |  | SHEET 1 OF 1 |

| Parts List |        |                        |  |
|------------|--------|------------------------|--|
| ITEM       | PART # | DESCRIPTION            | NOTES                                    |
| 1          | 1500   | Series 7 Radius Post   |  |
| 2          | 1550   | Series 7 Reveal/Filler | Tack weld or mechanically fasten to post |

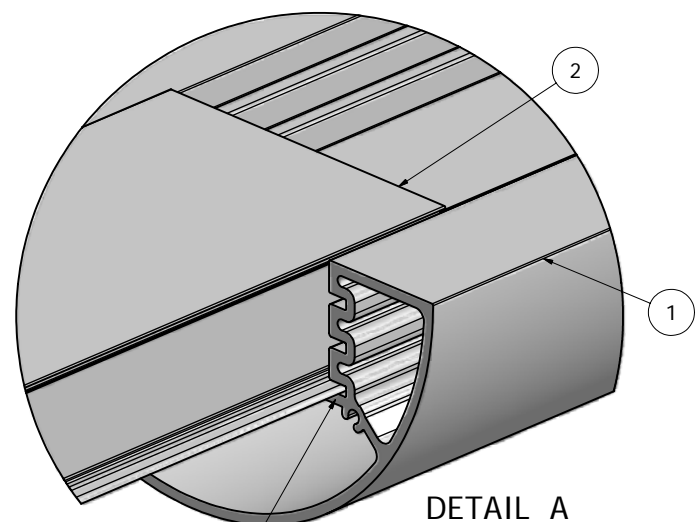
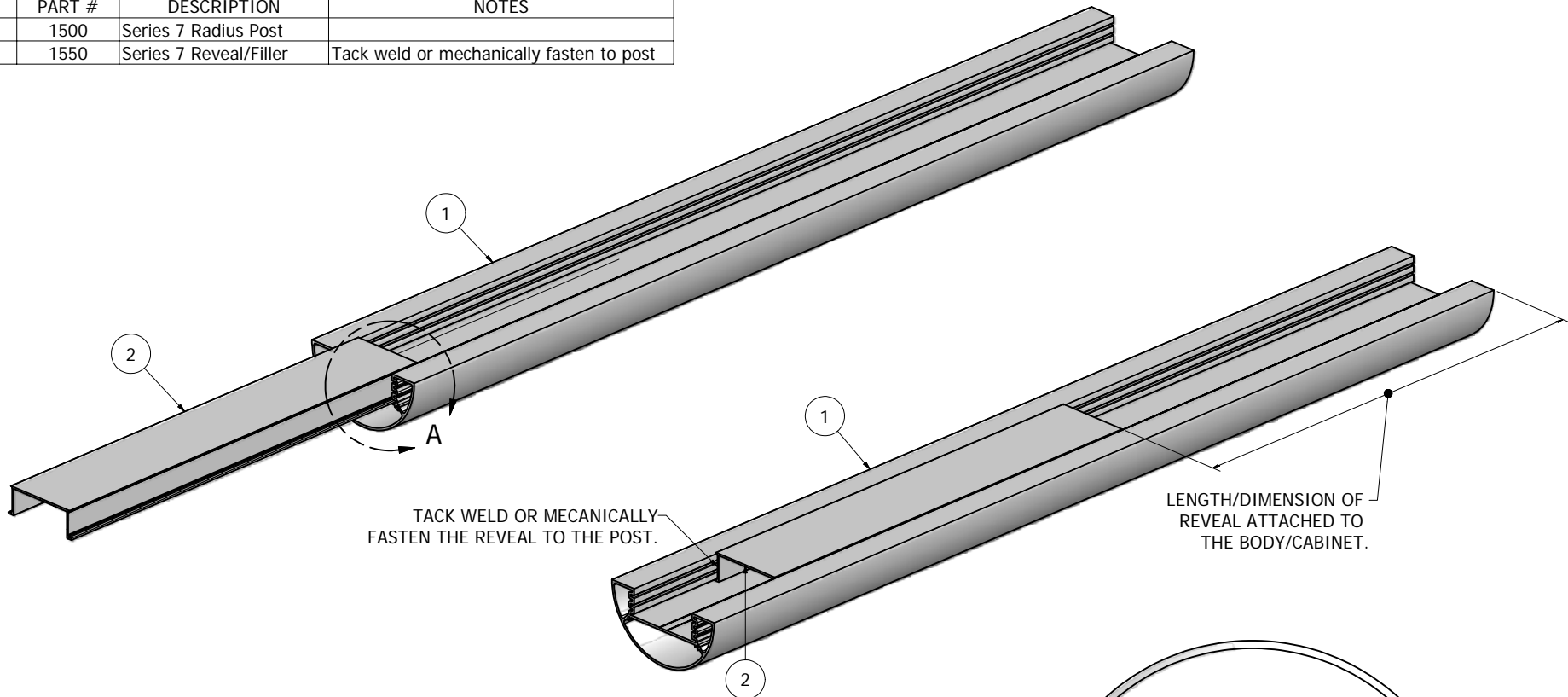

INSERT THE REVEAL/FILLER INTO THE ZERO REVEAL POSTION. SLIDED IT UP INTO THE POST.

Ship To:  
Order #:

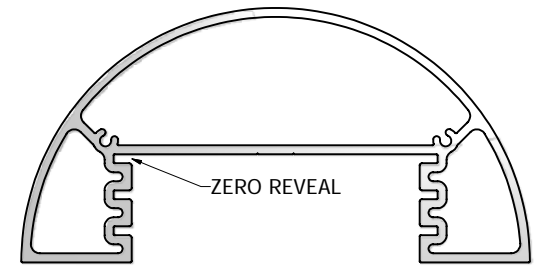

**NOTE: PRE-CUT KITS ARE NOT PRE-DRILLED.**  
(Holes shown in this drawing are for reference only. Drilling of pilot holes are to be done by fabricator.)

|   |          |   |              |
|---|----------|---|--------------|
| THIS DRAWING WAS CREATED AT NO CHARGE TO ASSIST YOU IN VISUALIZING OUR PROPOSAL. THE DRAWING HEREIN IS THE PROPERTY OF SIGNCOMP. PERMISSION TO COPY OR REVISE THIS DRAWING OR TO USE THIS DRAWING FOR PRODUCTION IS STRICTLY PROHIBITED AND CAN ONLY BE COPIED, REVISED OR USED FOR PRODUCTION WITH THE EXPRESSED WRITTEN PERMISSION OF SIGNCOMP. |          |   |              |
| DRAWN   | 8/5/2009 | <h1>SignComp</h1>                               |              |
| CHECKED   |          |   |              |
| QA  |          |   |              |
| MFG   |          |   |              |
| APPROVED  |          |   |              |
| TITLE   |          | Series 7 Radius Post and Reveal/Filler Assembly |              |
| SIZE  | C        | DWG NO  | K1500-50     |
| SCALE   |          |   | REV          |
|   |          |   | SHEET 1 OF 1 |